



GX5



AUSTRALIAN MADE

NYALIC
Clear Surface Protectant

Gear Boxes coated in Nyalic to help prevent corrosion.

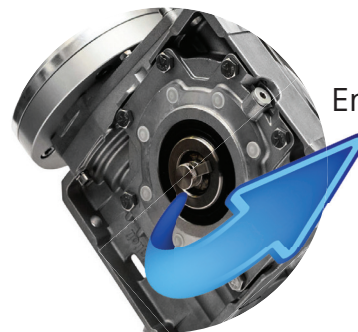

Emergency manual release

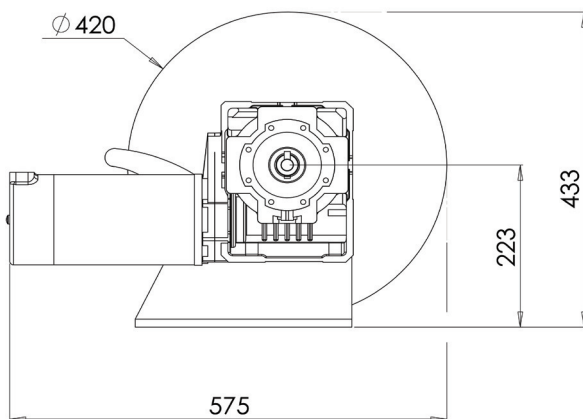

A monster of a unit, the GX5 and previous LSM model equivalents were at one time the largest electric drum anchor winches produced! The GX5 is the answer for large capacity trailer boat and commercial fishermen. Unrivalled in structural design and holding power, this model has been created for XHD loads and constant abuse with a 37mm solid machined shaft, 8mm frame and flanges, and 25mm solid frame stiffener. Thanks to the well oversized gearing and motor, this unit can easily be fitted to boats to 15m+ for saltwater use and much larger for freshwater applications.

- Huge 2300W (12V) or 2800W (24v) motor
- Perfect for wet wells and deck mounts
- Boats to 15m+
- Fast drop/retrieval rating
- 8mm 316SS plate construction
- Sealed IP68 motor and well oversized gearbox
- Emergency manual release
- 60kg approximate weight of unit

Installation kit includes: 400amp solenoid, 150amp circuit breaker, switch with panel, nuts and bolts.

Model	Motor Size	Drop/Retrieve	Max Pull (Empty Drum)	Max Pull (Full Drum)	Recc. Max Working Load	Rope/ Chain Capacity	Boat Size (metres)	Holding At Anchor
GX5 420mm drum	2300watts (12volt) 2800watts (24volt)	40metres per minute	2301kg (12volt model)	502kg (12volt model)	150kg	140m x 12mm + 12m x 10mm	15-20	7T